



VC-450

Vibrocoring System

The SEAS VC-450 is the most widely used and versatile of SEAS single core vibrocoring systems, catering for water depths to 200m and core samples up to 6.5m in length.

The SEAS VC-450 is a light weight highly efficient system which can be configured on-site for different coring conditions.

Its light weight modular design makes the VC-450 vibrocorer ideal for use on small vessels, enabling coring in very shallow water, estuarine, nearshore, lake and swamp environments as well as deeper water.



VC-450 drive unit

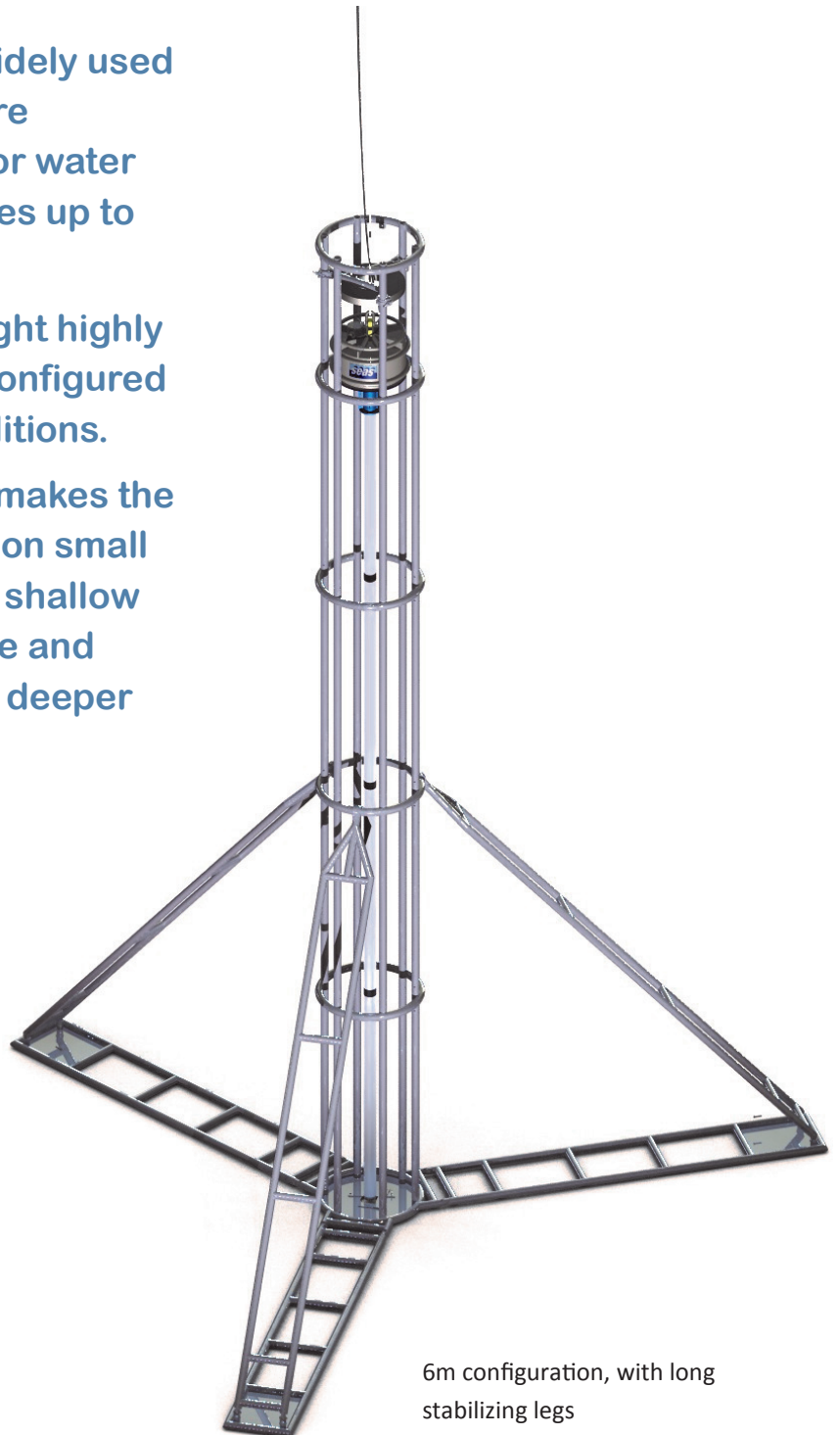

6m configuration, with long stabilizing legs

Submersible Equipment & Services Pty Ltd

Unit 4, 6 Hulberts Road, Toormina, NSW, 2452, AUSTRALIA

info@seasoffshore.com

www.seasoffshore.com

ph: +61 2 6658 3672

Specifications

Depth Rating	200 m
Core Length	Up to 6.5 m
Support Tower	
Height:	3.5m to 7m configurable on-site
Stabilising legs	Three legs at 120° separation. Long configuration: 2500mm legs, Seabed Footprint: 5950mm Short configuration: 1130mm legs, Seabed Footprint: 3215mm
Construction:	Tubular Aluminium alloy
Core marker	316 Stainless Steel
Weight in air	185kg (Including lead ballast weights)
Weight in water	135kg (Including lead ballast weights)
Vibrocoring Drive Unit	
Dimensions:	Diameter: 505mm Height: 405mm
Weight in air	110kg
Weight in water	85kg
System Power	415 vAC or 220 vAC 3Ø 50/60 Hz (Configurable to client specification and on-site conditions)
Power requirements	1.1kW, Maximum startup current: 6 amps (415vAC), 12 amps (220vAC) Compatible with shipboard 3Ø power or 10kVA 3Ø genset
Power Supply Cable	Seimens Hydrofirm 4-core sea cable: 1 x 50m length and 1 x 150 m extension with Sea Con underwater connectors.
Surface Control System	Residual Current Device (RCD) protected switch box and deck cable with remote switching.
Core Barrels:	Single-Use 80mm OD x 76mm ID Extruded Aluminium core tube. No core liners required. Core barrel serves as liner / storage vessel. On-Site surface processing can include cutting into manageable lengths (pipe-cutter) and capping or longitudinal slabbing (circular saw & knife).
Lifting gear required:	A-Frame or deck crane with SWL of 3 Tonnes maximum lift required for extracting core barrel from seabed (usually less lift is required unless coring in firm clay or very clean sands.)

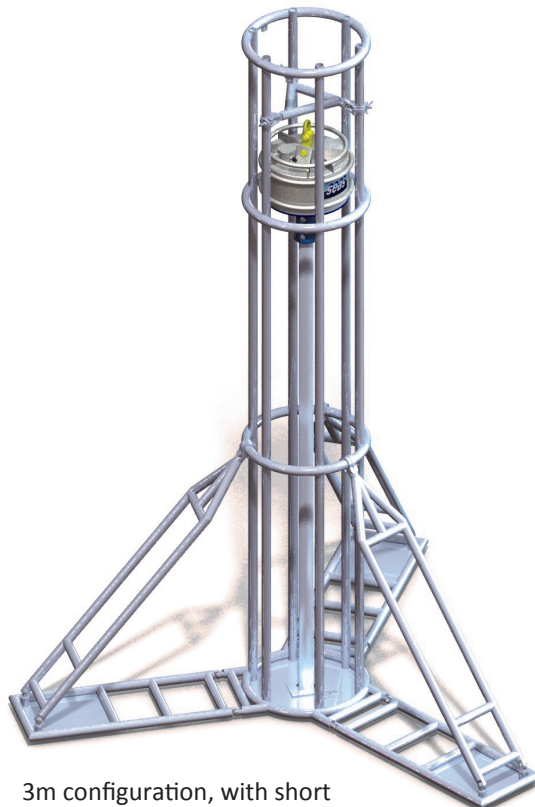

3m configuration, with short stabilizing legs